

**SPECIFICATIONS  
AND  
BID DOCUMENTS**



**LIBRARY INSIDE LIGHTING PROJECT  
RFP 2022-003**

**DEPARTMENT OF PUBLIC WORKS**

**501 MAIN STREET SOUTH**

**SOUTH BURY, CONNECTICUT**

**MAY 11, 2022**

# Table of Contents

Cover Page _____	1
Invitation to Bid _____	3
Information for Bidders _____	4
General Conditions _____	7
Code of Ethics _____	9
Scope of Work _____	16
Bid Proposal _____	17
Reflected Ceiling Plans _____	22
Original Approved Lighting Scope _____	25

# INVITATION TO BID

## LIBRARY INSIDE LIGHTING PROJECT RFP 2022-003

The Town of Southbury is seeking bids for the Library Inside Lighting Project located at 100 Poverty Road. Sealed bids will be received until **11:00 a.m., Wednesday, June 1, 2022**, at the Office of the First Selectman, Southbury Town Hall, 501 Main Street South, Southbury, Connecticut 06488, at which time all bids will be publicly opened and read aloud in the Conference Room 201 of the Town Hall. Any bid received after that time will be returned unopened.

Specifications and bidding documents are on file and may be reviewed at the Office of the First Selectman at the above address or obtained electronically from the Town's website at: [www.southbury-ct.org/bids](http://www.southbury-ct.org/bids). Prospective bidders shall examine the "Information for Bidders" and shall comply and conform strictly to the conditions and instructions contained therein. Requests For Information (RFIs) regarding this proposal are to be in writing and will be accepted until **4:00 p.m. on May 23, 2022**. RFIs are to be emailed to Gerald Lukowski, Director of Public Works at [publicworks@southbury-ct.gov](mailto:publicworks@southbury-ct.gov).

There will be a **mandatory** walk through at the library located 100 Poverty Road on Tuesday May 17, 2022 at 10:00 a.m.

The Town of Southbury reserves the right to reject any and all bids in whole or in part or to waive any informality in bidding if it is determined to be in the best interest of the Town of Southbury.

Bids may be held by the Town of Southbury for a period not to exceed forty-five (45) days from the date of the opening of bids for the purpose of reviewing the bids and investigating the qualifications of the bidder prior to awarding the contract.

Jeff Manville  
First Selectman  
May 2022

# INFORMATION FOR BIDDERS

## 1. PROPOSAL

Proposals are being sought for services to perform the Library Inside Lighting Project. All material shall be furnished in full accordance with the specifications.

## 2. RECEIPT AND OPENING OF BIDS

Separate sealed bids will be received in the Office of the First Selectman, Town Hall, 501 Main Street South, Southbury, Connecticut, 06488, until the time and date stated in the INVITATION TO BID. Bids shall then be publicly opened and read aloud.

All bids shall be submitted in sealed, opaque envelopes clearly labeled with the name of the bidder, his address, and the words **"BID DOCUMENTS, - Library Inside Lighting Project"** so as to guard against opening prior to the time set therefore. Bids may be forwarded by mail. If mailed, the sealed opaque envelope containing the proposal, marked as described above, shall be enclosed in another envelope properly addressed for mailing.

The Town may consider informal any bid not prepared and submitted in accordance with the provisions hereof and may waive any informalities in or reject any and all bids. Any bid may be withdrawn prior to the above scheduled time for the opening thereof.

## 3. PREPARATION OF PROPOSAL

Each bid must be submitted on the prescribed form and all blank spaces for bid prices must be filled, handwritten in ink or type written, in both words and figures. Bid prices shall include all labor, materials and equipment necessary to complete the work in accordance with the bid documents.

## 4. WITHDRAWAL OF BIDS

Bids may be withdrawn personally or on written or telegraphic request dispatched by the bidder in time for delivery in the normal course of business prior to the time fixed for opening, provided that written confirmation of any telegraphic withdrawal over the signature of the bidder is placed in the mail and postmarked prior to the time set for bid opening. Negligence on the part of the bidder in preparing his bid confers no right of withdrawal or modification of his bid after such bid has been opened.

## 5. FAMILIARITY WITH LAWS, SITE CONDITIONS AND DOCUMENTS

Each bidder is required to be familiar with and to comply with the terms and conditions of the specifications and all other Bid documents and with all Federal, State and Local laws, ordinances or regulations which in any manner relate to the furnishing of the services in accordance with the Bid.

Each bidder shall thoroughly familiarize himself with all conditions of the bid documents and specifications before preparing his proposal. The submission of a proposal shall be construed as an assurance that such examination has been made and the failure of the bidder to familiarize himself with conditions relating to the specifications shall in way relieve any bidder from any obligation in respect to his bid.

## 6. TAX EXEMPTION

The Town of Southbury is exempt from paying tax and, for that reason; the bid price shall not include any tax on the items specified.

## 7. QUALIFICATIONS OF BIDDER

Bidders must be regular full time contractors in the type of product or service specified. The Town may make such investigations as it deems necessary to determine the ability of the bidder to perform the work, and the bidder shall furnish to the Town all such information and data for this purpose as the Town may request. The Town reserves the right to reject any bid should the evidence submitted by, or investigation of, such bidder fails to satisfy the Town that such bidder is properly qualified to carry out the obligations of the Bid and to complete the project contemplated therein. Conditional bids will not be accepted.

## 8. ERRORS, INTERPRETATIONS AND ADDENDA

Should a bidder find any omissions, discrepancies or errors in the specifications or other Bid Documents or should he/she be in doubt as to the meaning of the Specifications or other Bid Documents, he/she should immediately notify the Town who may correct, amend or clarify such documents by a written interpretation or addendum. No oral interpretations shall be made to any bidder and no oral statement of the Town shall be effective to modify any of the provisions of the Bid Documents.

## 9. METHOD OF AWARD - LOWEST QUALIFIED BIDDER

The Town reserves the right to reject any or all bids and may waive any informalities.

The Bid will be awarded to the responsible bidder submitting the bid that results in the lowest net cost and best value to the Town while complying with all conditions set forth in these Bid Documents. The delivery date and other factors may be considered in the awarding of the Bid and may result in an award to a vendor other than the bidder quoting the lowest price. The experience and qualifications of the bidder shall be factors considered in the awarding of a bid and may result in an award to a vendor other than the low bidder. Preference may be given to equipment manufactured in the USA. In the event that there is a discrepancy between the price written in words and in figures, the price written in words shall govern.

## 10. SUBCONTRACTORS

The bidder is specifically advised that any person, firm or other party to whom it is proposed to award a subcontract under this Bid must be acceptable to the Town and that approval of the proposed subcontract award cannot be given by the Town unless and until the successful bidder submits all information and evidence requested by the Town regarding the proposed subcontractor. Although the bidder is not required to attach such information and evidence to his bid, the bidder is hereby advised of this requirement so that appropriate action can be taken to prevent subsequent delay in subcontract awards.

## 11. RIGHT OF THE TOWN TO TERMINATE PROJECT

In the event that any of the provisions of this Bid are violated by the Contractor, or by any of his subcontractors, the Town may serve written notice upon the Vendor of its intention to terminate the Work, such notices to contain the reasons for such intention to terminate the Work. Unless within five (5) days after the serving of such notice upon the Contractor, such violation or delay shall cease and satisfactory arrangement of correction be made, the project shall, upon expiration of said five (5) days, cease and terminate. In the event of any such termination, the Town shall immediately serve notice thereof upon the Contractor. In the event of such termination, the Town may take over the work or any portion thereof, and prosecute the same, by contract or any other method, for the account and at the expense of the Contractor, and the Contractor shall be liable to the Town for any excess cost occasioned by the Town as a result of such termination.

## 12. GUARANTEE

All equipment and materials including all parts and assemblies, if applicable, shall be guaranteed against defects in material and workmanship for a period of at least one (1) year after acceptance. Guarantee shall commence at the time of official acceptance by the Director of Public Works. Where it is required for the Contractor to repair, replace, resurface, replant or to modify, alter, add or remove hardware, parts, components, or related accessories for the purpose of insuring proper appearance, performance or operation, such work shall be done as required by the Contractor until such time as acceptable performance has been established.

Problems which occur shall be corrected in an appropriate fashion under guarantee. The Contractor shall be responsible to attend to and remedy such items within a reasonable amount of time. Appropriate logs, schedules shall be maintained to reflect these items and their redress.

## 13. PRE-BID CONFERENCE

A **mandatory** pre-bid conference will be held at the site at **100 Poverty Road**, Southbury, CT. at **10:00 A.M., Tuesday May 17, 2022**. At the specified time and place the proposed work site may be examined and a representative of the Town will answer questions regarding the bid documents.

## 14. SCHEDULING OF WORK

If notified of the acceptance of this proposal within the acceptance period, the bidder agrees to promptly schedule the work and submit verification of having scheduled the work within five (5) working days of such notice. The successful bidder shall promptly commence the work and prosecute the work diligently for the duration of the project. Each bidder shall furnish the number of days needed to complete the work (from notice to proceed to finish) with his bid. The Contractor's committed schedule to execute the entire work will be considered along with the submitted price in determining the successful bidder. Prospective bidders are advised that time is of the essence of this Contract.

## GENERAL CONDITIONS

The Director of Public Works shall be the Contractor's direct contact and periodic conferences will be held to review the status of work progress.

The Contractor shall employ only honest and responsible employees, skilled in the tasks assigned to them. The Contractor shall be responsible for all conduct of his employees.

All work shall be completed in a thoroughly professional and workmanlike manner in strict accordance with the Bid Documents.

The Town of Southbury reserves the right to establish the order of priority for completion of the various portions of the work and to delete any portion of the work upon notification of the Contractor.

The Contractor agrees to indemnify the Town against and save the Town harmless from any and all liability and loss from any claim, suit, or action based upon any alleged injury or death of any person including any employee of the Contractor or subcontractor, and for damage to any property that may occur or that may be alleged to have occurred in the course of the performance of the work, or from failure to guard the same, whether such act or failure to act is by the Contractor of any subcontractor or anyone directly or indirectly employed by any of them or by anyone for whose acts any of them maybe liable, and the Contractor agrees at its own expense to pay all charges for attorneys in connection with the defense against any such claim, and if any judgment should be rendered against the Town in any such action, the Contractor will satisfy and discharge the same without cost or expense to the Town.

Before commencing work, the Contractor shall obtain and deliver certificates of insurance to the Director of Public Works and during the performance of the work, the Contractor shall maintain insurance of the kinds and in at least the amounts specified hereunder in a form satisfactory to the Town; such certificates shall contain a provision that the Town shall be given thirty (30) days advance written notice by registered mail of, modification, change, termination, cancellation or expiration of, coverage. Renewal certificates shall be provided at least 60 days prior to expiration of the policy. With each Certificate of Insurance, the contractor shall provide a separate endorsement naming the Town of Southbury as an "Additional Insured". Such endorsement shall include the following language "The Town of Southbury is an additional named insured." The cost of such insurance shall be the sole responsibility of the Contractor. The Contractor shall require each Subcontractor employed on the Project to maintain the coverage listed below unless the Contractor's insurance covers activities of the Subcontractor on the Project.

1. Worker's Compensation Coverage and Employer's Liability Coverage A at Statutory Limits in accordance Connecticut Law and Coverage B at limits of \$100,000/\$500,000/\$100,000.

2. Broad Form Commercial General Liability including premises and operations, products, completed operations, contractual liability, independent contractors, and broad form property damage coverage, written on a "per occurrence" basis with minimum combined coverage for bodily injury, personal injury, and property damage liability of \$2,000,000 general annual aggregate, \$ 1,000,000 per occurrence and \$2,000,000 Products/Completed Operations Aggregate.

3. Comprehensive Automobile Liability, covering all vehicles used by Contractor in the course of work, including owned, non-owned and hired with minimum coverage of \$2,000,000 combined single limit for bodily injury and property damage.

4. Excess Liability with minimum coverage of \$ 2,000,000 in umbrella form.

If any policy is written on a "Claims Made" basis the retroactive date must be prior to or coincident with the date of the Contract and the Certificate shall state that the coverage is "claims made" and shall also state the retroactive date. The policy must be continually renewed for a minimum of two years from the completion date of the contract or the Contractor must purchase an Extended Reporting Period endorsement or shall purchase Prior Acts Coverage.

All Coverage is to be provided on a primary noncontributory basis.

All insurance shall be provided by a company authorized to do business in the State of Connecticut and having an A.M. Best rating of no less than A-VIII.

The insurer shall agree to waive all rights of subrogation against the Town of Southbury, its officers, officials, and employees for losses arising from work performed by the Contractor for the Town.

No insurance required or furnished hereunder shall in any way relieve the Contractor of or diminish any of his responsibilities, obligations and liabilities under the Contract.

The successful Bidder shall, within ten (10) days after notification of award, furnish a Performance Bond in the amount of one hundred percent (100%) of the Contract sum as awarded and a Labor and Material Payment Bond in the amount of one hundred percent(100%) of the Contract sum as awarded, as security for the faithful performance of the Contract, and for the payment of all persons, firms or corporations to whom the Contractor may become legally indebted for labor, materials, tools, equipment, or services of any nature including utility and transportation services, employed or used by him in performing the work. Such bonds shall be in the same form as that included in the bid Documents or a form acceptable to the Director of Public Works and shall bear the same date as, or a date subsequent to that of the Agreement. The current power of attorney for the person who signs for any surety company shall be attached to such bonds. These bonds shall be signed by a Guaranty or Surety Company listed in the latest issue of the U.S. Treasury Circular 570 and the amount shall be within the maximum specified for such Company in said Circular 570.



## Code of Ethics/Conflict of Interest Ordinance

### A. Definitions.

The following definitions shall apply to this Ordinance:

1. **Public Official** (or Public Office). An elected or appointed official, whether paid or unpaid, full or part-time, of the Town of Southbury. This includes being a member or alternate member of any board, committee, commission or agency that exists in the Town of Southbury government.
2. **Town Employee** (or Town Employment). A paid employee, full or part-time, of the Town of Southbury.
3. **Ethics Commission**. The Town of Southbury Commission on Ethics as authorized by Section 7-148h of the Connecticut General Statutes.
4. **Conflict of Interest**. A conflict of interest shall be deemed to exist if any Public Official or Town Employee has a Direct Interest or an Indirect Interest, in any purchase, contract, transaction, or decision involving his/her office, board, commission, agency or employment.
5. **Direct Interest**. An interest of a Public Official or Town Employee or any business, investment, or property in which such Public Official or Town Employee is an owner, member, partner, officer, employee or stockholder or has any other form of participation, that is a Financial Interest or an Adverse Interest in any purchase, contract, transaction or decision involving his or her office, board, committee, commission, agency or employment.
6. **Indirect Interest**. An interest of a family member within the fourth degree by blood or marriage or a person engaged in a close business relationship with a Public Official or Town Employee in any purchase, contract, transaction or decision involving the Public Official's or Town Employee's office, board, committee, commission, agency or employment which, if held by the Public Official or Town Employee directly, would meet the definition of a Direct Interest.
7. **Financial Interest**. A Financial Interest shall be deemed to exist if a person or entity with a Direct Interest or an Indirect Interest as defined herein might, directly or indirectly, derive pecuniary or financial gain or suffer loss from any Town purchase, contract, transaction, decision or employment.
8. **Adverse Interest**. An interest that is adverse to the interests of the Town with respect to the matter under consideration.

Approved by the Board of Selectmen 2/2/17  
Effective February 27, 2017

9. **Material Conflict of Interest.** A conflict of interest shall be deemed to be material where a reasonable person would conclude that a Financial Interest or Adverse Interest:

- a. is incompatible, or would to a reasonable person appear to be incompatible, with the proper discharge of official duties; or
- b. would tend to impair, or would to a reasonable person appear to impair, independence of judgment and action in the performance of official duties.

## **B. Declaration of Policy.**

1. The proper operation of the government of the Town of Southbury requires that Public Officials and Town Employees be independent, impartial and responsible to the people; that governmental decisions and policies be made in the proper channels of the government structure and free from coercive or other improper influence; that Public Officials and Town Employees not use their positions for personal gain; and that the general public have confidence in the integrity of its government.
2. This Ordinance sets forth standards of ethical conduct to maintain and enhance responsible and effective public service by our Public Officials and Town Employees in the performance of their duties.
3. In the interest of ensuring that concerns regarding possible conflict of interests are promptly raised, this Ordinance permits a concern that a conflict of interest may exist to be raised by any person, regardless of whether the person would be considered an aggrieved party as that term is interpreted under Connecticut law. Any failure to observe the procedures set forth in this Ordinance shall not, however, afford a basis for an action for damages against the Town, any Town board, committee, commission, agency or employee, or any member of any Town board, committee, commission, or agency, or for challenging a decision, license, permit or other action of a Town Employee, board, committee, commission or agency or member of same by a person who would not, but for the provisions of this Ordinance, have standing to bring such an action.

## **C. Disclosure of Conflict.**

1. Any Public official or Town Employee who has a conflict or potential conflict of interest as defined herein, whether or not such conflict or potential conflict is material, shall disclose the interest causing such conflict or potential conflict in writing to the Board of Selectmen.

Approved by the Board of Selectmen 2/2/17  
Effective February 27, 2017

2. Any Public Official or Town Employee who is a member of any Town board, committee, commission or agency who has a conflict or potential conflict of interest as defined herein, whether or not such conflict or potential conflict is material, shall, in addition to the disclosure required by this Ordinance, disclose the interest causing such conflict to such board, committee, commission, or agency and such disclosure shall be recorded in the board's, committee's, commission's or agency's minutes.

#### **D. Determination of Materiality.**

1. In the event that a disclosure or a claim of a conflict of interest with respect to any Public Official or Town Employee has been made to the Ethics Commission, and the Public Official or Town Employee does not disqualify himself/herself from matters with respect to which the conflict of interest allegedly exists, the Ethics Commission shall promptly inquire into the facts of the matter and determine whether or not a conflict exists and if so, whether it is material.

2. In the event that a disclosure or a claim or a conflict of interest with respect to any Public Official or Town Employee who is a member of a Town board, committee, commission or agency has been made to such board, committee, commission, or agency and the member does not disqualify himself/herself from matters with respect to which the conflict of interest allegedly exists, the board, committee, commission or agency shall forthwith determine by a majority of those members present, excluding the member whose interest is in question, whether or not a conflict exists and, if so, whether it is material.

#### **E. Disqualification.**

If it has been determined that a material conflict of interest exists, the Public Official or Town Employee who has the conflict shall be disqualified from discussing or acting upon any matter encompassed by that conflict of interest, and shall leave the room during any public hearing, discussions or deliberations regarding the matter. Any Public Official or Town Employee may disqualify himself/herself even though the conflict of interest is not material.

#### **F. Claim of Conflict.**

If a formal written complaint is made to the Ethics Commission that any Public Official or Town Employee has an undisclosed conflict of interest, the Ethics Commission shall record and act upon the claim in accordance with its procedures as outlined in Section J.

#### **G. Gifts and Favors.**

Approved by the Board of Selectmen 2/2/17  
Effective February 27, 2017

No Public Official or Town Employee shall accept or receive, directly or indirectly, anything of value (whether by rebate, gift, promise, obligation or contract for future reward or compensation or otherwise) for awarding or influencing the award of any decision, permit, license, contract or purchase order by the Town. Anything of value when in the form of a gift shall not be deemed relevant if the actual cost of that item is less than \$25.00.

## **H. Representation.**

1. Without the prior written consent of the Ethics Commission, no Public official or Town Employee shall appear for compensation, except on behalf of the town, before any Town board or agency in which he/she was formerly employed or served as an official at any time within a period of one (1) year after termination of his/her service with the Town.
2. Without the prior written consent of the Ethics Commission, no current or former Public Official or Town Employee shall represent anyone other than the Town concerning any particular matter in which he/she participated personally and substantially while in municipal service.
3. No current or former Public Official or Town Employee shall disclose or use confidential information acquired in the course of and by reason of his/her official duties, for personal and/or financial gain for himself/herself or others.
4. No former Public Official or Town Employee who participated substantially in the negotiation or award of municipal contract or who supervised the negotiation or award of such a contract shall accept employment with a party to the contract other than the Town for a period of one (1) year after such contract is signed.

## **I. Independent Contractors.**

Before hiring any consultant, independent contractor or other advisor, the Public Official, Town Employee, board, committee, commission or agency that proposes to hire the independent contractor shall inquire whether the independent contractor has any conflict of interest as that term is defined in this Ordinance or as defined in any code of ethics or similar code applicable to the independent contractor. Any such conflict shall be specified in the appropriate Town records (such as minutes of any relevant board, committee, commission, or agency). Prior to hiring any independent contractor with a conflict, the Public Official, Town Employee, board, committee, commission or agency proposing to hire the independent contractor must make a determination that the conflict is not material and/or that despite the conflict, the independent contractor should be hired. The decision and the reasons therefore must be a matter of public record.

Approved by the Board of Selectmen 2/2/17  
Effective February 27, 2017

No consultant, independent contractor or other advisor of the Town shall represent a private interest in any action or proceeding against the interest of the Town which is in conflict with the performance of his/her duties as such consultant, independent contractor or advisor. No consultant, independent contractor or advisor may represent anyone other than the Town concerning any matter in which he/she participated personally and substantially as a consultant to the Town. Neither shall such consultant, independent contractor or advisor disclose confidential information acquired while performing his/her duties for the Town, nor shall he/she use such information for the personal and/or financial interests of himself/herself or others.

#### **J. Procedure.**

All claims pertaining to a violation of this Ordinance shall be made, in writing, to the Ethics Commission in accordance with the rules and regulations promulgated by that Commission which shall be found in the Town of Southbury Ethics Commission Statement of Procedures. These rules shall require the Complainant to specify the facts that gave rise to his/her claim and the specific provision of this Ordinance that has been breached on a Form provided by the Ethics Commission. The Ethics Commission may, but is not required to consider claims made against individuals who are former Public Officials or Town Employees. Any allegations and any information learned, supplied to or received from or by the Ethics Commission shall remain confidential until a finding of Probable Cause is determined by the Ethics Commission.

The Ethics Commission is authorized to issue advisory opinions at its discretion.

#### **K. Penalties.**

1. Any person who violates any of the provisions of this Ordinance may be censured or reprimanded or may be suspended or removed from Public Office or Town Employment, as the case may be, in the manner provided by law as recommended by the Ethics Commission with action by the Board of Selectman.
2. Any violation of this Ordinance shall render any purchase, contract, or transaction or any part thereof affected thereby voidable as recommended by the Ethics Commission with action by the Board of Selectmen.
3. Any violation of this Ordinance with respect to any decision of a board, committee, commission or agency shall be subject to any remedies deemed proper as recommended by the Ethics Commission with action by the Board of Selectmen and permitted by law.
4. The penalties provided above are in addition to any other penalties provided by law to address violations of the provisions of this Ordinance.

Approved by the Board of Selectmen 2/2/17  
Effective February 27, 2017

## **L. Concurrent Offices.**

1. No Town Employee shall serve on any board, committee, commission or agency to which the Town Employee reports or acts as staff, except as otherwise stated in the Town Charter or Ordinances. Notwithstanding the foregoing, a Town Employee may serve on any board, committee, commission or agency in an advisory capacity.
2. Except as otherwise provided in the Charter or by Ordinance, the First Selectman, the Selectmen, the Town Clerk, members of the Board of Finance and members of the Ethics Commission shall hold no other Public Office, and the provisions of Section 9-210 of the General Statutes concerning incompatible Town offices shall apply to the officers described therein.
3. The restrictions set forth in Section L. 1 and Section L. 2 shall not apply to membership on any temporary or advisory only committee, task force, working group, or the like.
4. Subject to the restrictions set forth in applicable law, or by the Charter or by Ordinance, and in Section L. 2 of this Ordinance, nothing in this Ordinance shall prevent the appointment of the same person to more than one Public Office, provided the offices are not incompatible, provided the duties of the offices to which he/she is appointed may, in the opinion of the Ethics Commission, be satisfactorily fulfilled by one person, and provided further that inability to fulfill satisfactorily the duties of all offices to which he is appointed shall be cause for removal from any one or more of said offices.

## **M. Meetings.**

1. **Members Attendance.** Public Officials who are members of boards, committees, commissions, and agencies are expected to attend all meetings of such boards, committees, commissions and agencies or attend meetings in accordance with the by-laws or other duly adopted rules of the group to which they belong. However, it shall not be deemed to be a violation of this Ordinance if Public Officials who are members of boards, committees, commissions, and agencies comply with the standards set forth in Section 512 of the Town Charter. For the purposes of this Ordinance only, the attendance standards set forth in Section 512 shall apply to both elected and appointed members of boards, committees, commissions and agencies.
2. **Alternates' Attendance.** Public Officials who are alternate members of boards, committees, commissions and agencies are expected to attend all meetings of such boards, committees, commissions and agencies, or attend meetings in accordance with the by-laws or other duly adopted rules of the group to which

Approved by the Board of Selectmen 2/2/17  
Effective February 27, 2017

they belong. However, it shall not be deemed to be a violation of this Ordinance if Public Officials who are alternate members of boards, committees, commissions and agencies comply with the standards set forth in Section 512 of the Town Charter. For the purposes of this Ordinance only, the attendance standards set forth in Section 512 shall apply to both elected and appointed alternate members of boards, committees, commissions and agencies.

3. Voting. All Public Official members or seated alternate members of boards, committees, commissions and agencies who are qualified to vote, shall vote on all matters upon which a vote is held by such board, committee, commission or agency unless there shall be reasonable cause for abstention and said cause is stated and recorded in the minutes of the meeting.

4. Statement of Reasons. In every case where the action of any board, committee, commission or agency is subject to a right of appeal to another administrative body or to the courts of the State of Connecticut, a statement of the reasons for its action shall be included in the minutes of the meeting.

Approved by the Board of Selectmen 2/2/17  
Effective February 27, 2017

## RFP 2022-003

### SCOPE OF WORK

#### LIBRARY INSIDE LIGHTING

The Town of Southbury is requesting proposals for interior energy efficiency upgrades at the Public Library located at 100 Poverty Road. The work will be completed in strict accordance with the requirements set forth by Eversource in its capacity as administrator for the Connecticut Energy Efficiency Fund. **Only contractors with prior successful experience on projects receiving incentive payments thru the fund will be considered.** References on past projects must be provided on the bid form.

The scope of work includes but is not necessarily limited to the following:

- The contractor shall ensure the installed Energy Efficiency Measures (EEMs) comply with the requirements listed in section 11 of the RFP and verify the EEMs perform in their intended manner
- The contractor shall provide all schedules, manufactures data and other information required by Eversource to maximize the incentive rebate.
- The contractor shall coordinate the work with the Department of Public works for the purpose of accessing private offices, conference rooms and the like.
- The contractor shall file and obtain an electrical permit. The fee for the permit is waived.
- Replacement lamps shall be a color temperature of 3500K.
- Upon completion coordinate a final inspection with Eversource and the Director of Public Works.
- Note the large dome pendant fixtures type A and AE have been previously retrofitted and are excluded from this proposal.
- Light fixtures at the main entrance covered walkway are specifically excluded.
- The scope of work includes the installation of occupancy sensors.
- Scope of work includes the installation of 14 ea. faucet aerators with units having a flow rates of 1.5 gpm. or less.
- The contractor is responsible to properly dispose existing lamps, ballasts and debris. Trash can be disposed at the Town Transfer station located at 231 Kettle town Rd. at no cost to the contractor.
- Reflected ceiling plans provided in section 10 of the RFP are provided for the convenience of the contractor. It is the contractor's responsibility to field verify the existing conditions and submit their bid based on the actual fixtures in place.
- The contractor shall provide temporary protection as required. The work area will be completely cleaned at the end of each day.



**BID PROPOSAL**



**TOWN OF SOUTHBURY**

**LIBRARY INSIDE LIGHTING PROJECT**

TO: Mr. Jeff Manville  
First Selectman  
501 Main Street South  
Southbury, Connecticut 06488

PROPOSAL OF:

NAME OF COMPANY: \_\_\_\_\_

FOR: Library Inside Lighting Project

The undersigned declares that he/she has thoroughly reviewed the specifications and all other bidding documents, dated May 11, 2022, and that, if his/her bid is accepted, he/she will complete the Library Inside Lighting Project for the Town of Southbury and that he/she will take in full payment therefore, the price for completing the project.

1. Energy Upgrades                      Numerical Amount \$ \_\_\_\_\_  
Written Amount \_\_\_\_\_

2. Estimated Incentive                      Numerical Amount \$ \_\_\_\_\_  
Written Amount \_\_\_\_\_

- 3. Net Cost                      Numerical Amount \$ \_\_\_\_\_  
     Written Amount \_\_\_\_\_
  
- 4. Projected Monthly Savings    Numerical Amount \$ \_\_\_\_\_
  
- 5. Payback Period                      \_\_\_\_\_

**COMPLETION TIME:** The work to be completed within \_\_\_\_\_ calendar days from the date of the Town’s authorization to proceed.

**REFERANCES**

Project Name                      \_\_\_\_\_  
 Client                                      \_\_\_\_\_  
 Contact Name                      \_\_\_\_\_  
 Phone                                      \_\_\_\_\_  
 Completion Date                      \_\_\_\_\_  
 Cost                                      \_\_\_\_\_  
 Rebate                                      \_\_\_\_\_

Project Name                      \_\_\_\_\_  
 Client                                      \_\_\_\_\_  
 Contact Name                      \_\_\_\_\_  
 Phone                                      \_\_\_\_\_  
 Completion Date                      \_\_\_\_\_  
 Cost                                      \_\_\_\_\_  
 Rebate                                      \_\_\_\_\_

Project Name                      \_\_\_\_\_  
 Client                                      \_\_\_\_\_  
 Contact Name                      \_\_\_\_\_  
 Phone                                      \_\_\_\_\_  
 Completion Date                      \_\_\_\_\_  
 Cost                                      \_\_\_\_\_  
 Rebate                                      \_\_\_\_\_

It is understood that the Town of Southbury reserves the right to add or delete work at its sole discretion.

\_\_\_\_\_  
(Legal Company Name)

\_\_\_\_\_  
(Signature of Authorized Representative) L.S.

\_\_\_\_\_  
(Title of Authorized Representative)

\_\_\_\_\_  
(Business Address)

\_\_\_\_\_  
(City, State and Zip Code)

\_\_\_\_\_  
(Date)

(        ) \_\_\_\_\_  
(Telephone Number)

\_\_\_\_\_  
( E-MAIL)

**NOTICE TO CONTRACTORS – CODE OF ETHICS/CONFLICT OF INTEREST  
ORDINANCE**

The Town of Southbury has amended its Code of Ethics/Conflict of Interest Ordinance that became effective **on February 28, 2017** and is included in this package. The Contractor shall comply with all applicable provisions of said Ordinance. The Contractor acknowledges receiving a copy of said Ordinance, a copy of which is attached hereto and made a part hereof. The Contractor further agrees that any instance of its violating any provisions of the Code of Ethics/Conflict of Interest Ordinance will be sufficient cause for the Town to terminate any or all of the Contractor's contracts or pending contracts with the Town. The Contractor agrees that the above clause will also be incorporated in all of its contracts with its subcontractors and consultants.

**ACKNOWLEDGEMENT OF RECEIPT**

I have read the above Code of Ethics/Conflict of Interest Ordinance, and agree to abide by its terms.

ORDINANCE RECEIVED BY: \_\_\_\_\_ (Print name)

\_\_\_\_\_ (Signature)

\_\_\_\_\_ Date)

The successful bidder must submit satisfactory proof of insurance and a signed Indemnification Certificate.

## INDEMNIFICATION CERTIFICATE

To the fullest extent permitted by law, the contractor shall indemnify and hold harmless the Town of Southbury, and agents and employees of said Town from and against claims, damages, losses and expenses, including but not limited to attorney's fees, arising out of or resulting from performance of the work, provided that such claim, damage, loss or expense is attributable to bodily injury, sickness, disease or death, or to injury to or destruction of tangible property (other than the work itself) including loss or use resulting therefrom, but only to the extent caused in whole or in part by acts or omissions of the contractor, a subcontractor, anyone directly or indirectly employed by them or anyone for whose acts they may be liable, regardless of whether or not such claim, damage, loss or expense is caused in part by a party indemnified hereunder.

Such obligation shall not be construed to negate, abridge, or reduce other rights or obligations of indemnity which would otherwise exist as to the Town of Southbury. In claims against any person or entity indemnified under this paragraph by an employee of the contractor, a subcontractor, anyone directly or indirectly employed by them or anyone for whose acts they may be liable, the indemnification obligation under this paragraph shall not be limited by a limitation on amount or type of damages, compensation or benefits payable by or for the contractor or a subcontractor under workers' or workmen's compensation acts, disability benefits acts or other employee benefits acts.

---

CONTRACTOR

BY:

---

Authorized Signature & Title

---

Address

---

Date

PROPOSED LIBRARY BUILDING FOR  
**SOUTHBURY PUBLIC LIBRARY**  
SOUTHBURY, CONNECTICUT

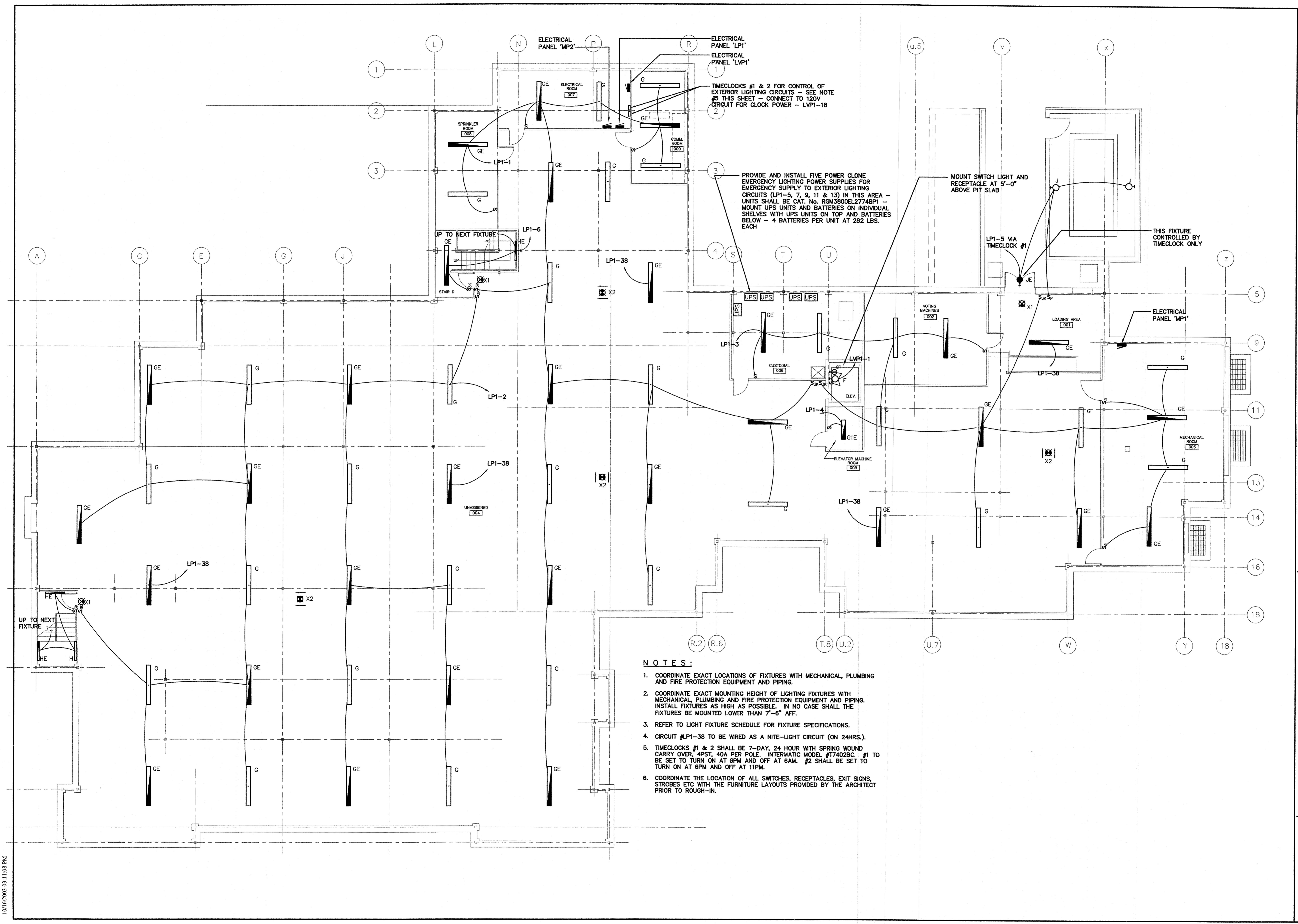

**NOTES:**

- COORDINATE EXACT LOCATIONS OF FIXTURES WITH MECHANICAL, PLUMBING AND FIRE PROTECTION EQUIPMENT AND PIPING.
- COORDINATE EXACT MOUNTING HEIGHT OF LIGHTING FIXTURES WITH MECHANICAL, PLUMBING AND FIRE PROTECTION EQUIPMENT AND PIPING. INSTALL FIXTURES AS HIGH AS POSSIBLE. IN NO CASE SHALL THE FIXTURES BE MOUNTED LOWER THAN 7'-6" AFF.
- REFER TO LIGHT FIXTURE SCHEDULE FOR FIXTURE SPECIFICATIONS.
- CIRCUIT #LP1-38 TO BE WIRED AS A NITE-LIGHT CIRCUIT (ON 24HRS.).
- TIMELOCKS #1 & 2 SHALL BE 7-DAY, 24 HOUR WITH SPRING WOUND CARRY OVER, 4PST, 40A PER POLE. INTERMATIC MODEL #T7402BC. #1 TO BE SET TO TURN ON AT 6PM AND OFF AT 6AM. #2 SHALL BE SET TO TURN ON AT 6PM AND OFF AT 11PM.
- COORDINATE THE LOCATION OF ALL SWITCHES, RECEPTACLES, EXIT SIGNS, STROBES ETC WITH THE FURNITURE LAYOUTS PROVIDED BY THE ARCHITECT PRIOR TO ROUGH-IN.

10/16/2003 03:11:08 PM

PROPOSED LIBRARY BUILDING FOR  
**SOUTHURY PUBLIC LIBRARY**  
SOUTHURY, CONNECTICUT

PHONE: (860) 677-0660 FAX: (860) 676-9237  
13 WATERBURY COURT, AVON, CONNECTICUT 06001

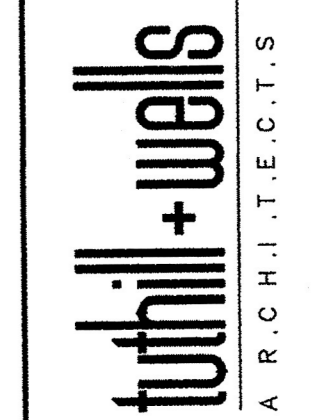

DATE 10/21/03  
SCALE 1/8"=1'-0"  
JOB NUMBER  
**FIRST FLOOR LIGHTING PLAN**  
DRAWING NUMBER  
**E1.02**

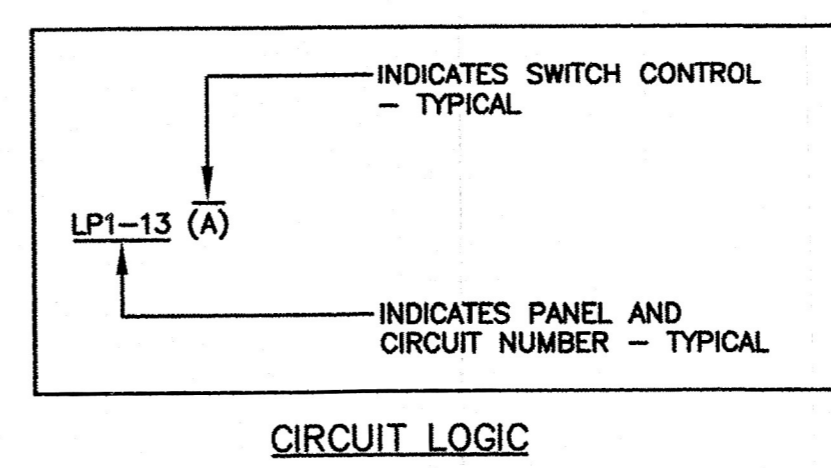
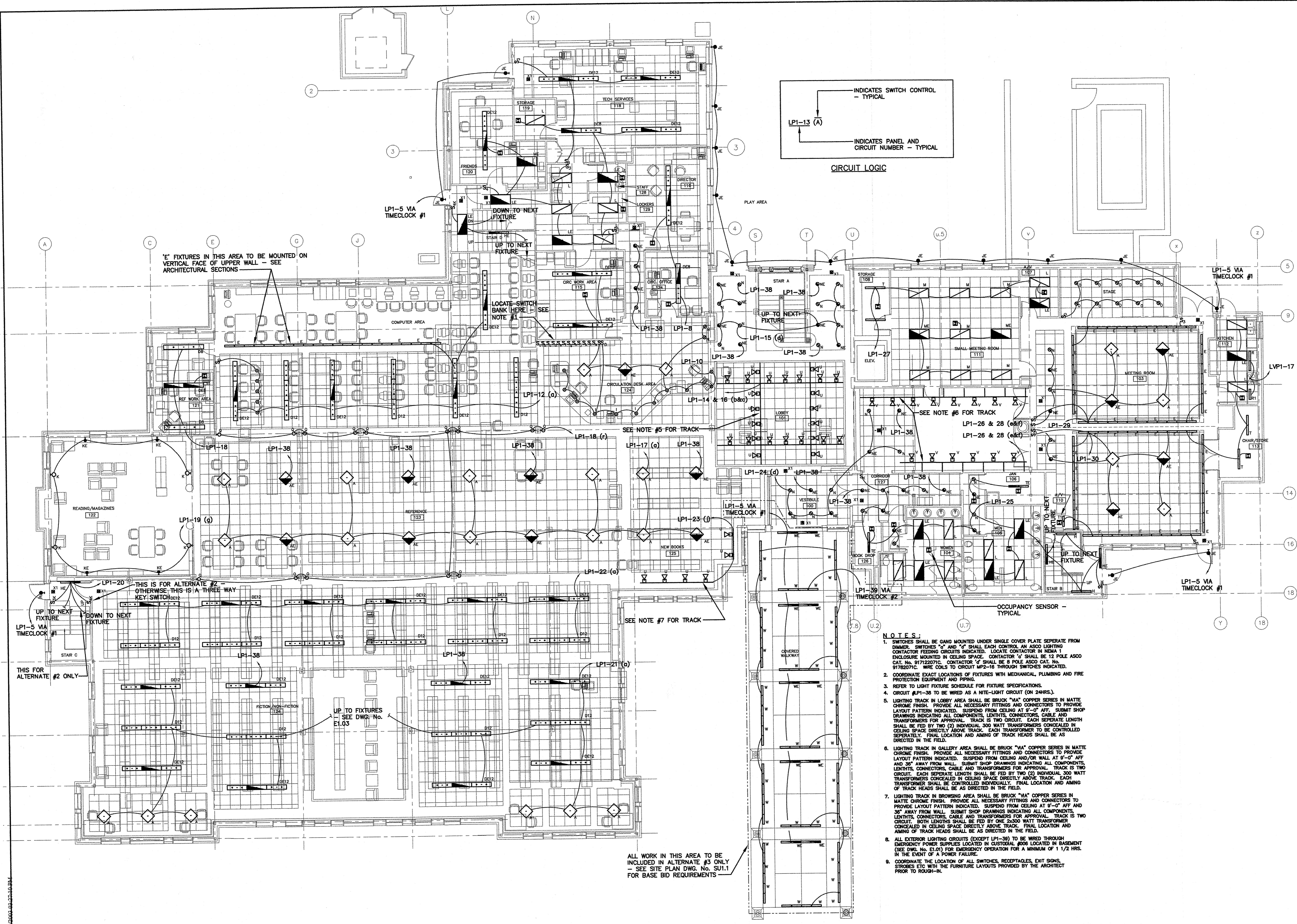

CIRCUIT LOGIC

NOTES:

- SWITCHES SHALL BE GANG MOUNTED UNDER SINGLE COVER PLATE SEPERATE FROM DIMMER. SWITCHES "0" AND "2" SHALL EACH CONTROL AN ASSOC LIGHTING CONTACTOR FEEDING CIRCUITS INDICATED. LOCATE CONTACTOR IN NSMA-1 ENCLOSURE MOUNTED IN CEILING SPACE. CONTACTOR "0" SHALL BE 12 POLE ASSO CAT. No. 917122071C. CONTACTOR "2" SHALL BE 8 POLE ASSO CAT. No. 9172071C. WIRE COALS TO CIRCUIT #P2-16 THROUGH SWITCHES INDICATED.
- COORDINATE EXACT LOCATIONS OF FIXTURES WITH MECHANICAL, PLUMBING AND FIRE PROTECTION EQUIPMENT AND PIPING.
- REFER TO LIGHT FIXTURE SCHEDULE FOR FIXTURE SPECIFICATIONS.
- CIRCUIT #LP1-38 TO BE WIRED AS A WYE-LIGHT CIRCUIT (ON 24HRS.).
- LIGHTING TRACK IN LOBBY AREA SHALL BE BRUCK "M" COPPER SERIES IN MATTE CHROME FINISH. PROVIDE ALL NECESSARY FITTINGS AND CONNECTORS TO PROVIDE LAYOUT PATTERN INDICATED. SUSPEND FROM CEILING AT 9'-0" AFF. SUBMIT SHOP DRAWINGS INDICATING ALL COMPONENTS, LEVITTS, CONNECTORS, CABLE AND TRANSFORMERS FOR APPROVAL. TRACK IS TWO CIRCUIT. EACH SEPERATE LENGTH SHALL BE FED BY TWO (2) INDIVIDUAL 300 WATT TRANSFORMERS CONCEALED IN CEILING SPACE DIRECTLY ABOVE TRACK. EACH TRANSFORMER TO BE CONTROLLED SEPERATELY. FINAL LOCATION AND AIMING OF TRACK HEADS SHALL BE AS DIRECTED IN THE FIELD.
- LIGHTING TRACK IN BROWSING AREA SHALL BE BRUCK "M" COPPER SERIES IN MATTE CHROME FINISH. PROVIDE ALL NECESSARY FITTINGS AND CONNECTORS TO PROVIDE LAYOUT PATTERN INDICATED. SUSPEND FROM CEILING AT 9'-0" AFF AND 38" AWAY FROM WALL. SUBMIT SHOP DRAWINGS INDICATING ALL COMPONENTS, LEVITTS, CONNECTORS, CABLE AND TRANSFORMERS FOR APPROVAL. TRACK IS TWO CIRCUIT. BOTH LENGTHS SHALL BE FED BY ONE 2x300 WATT TRANSFORMER CONCEALED IN CEILING SPACE DIRECTLY ABOVE TRACK. FINAL LOCATION AND AIMING OF TRACK HEADS SHALL BE AS DIRECTED IN THE FIELD.
- ALL EXTERIOR LIGHTING CIRCUITS (EXCEPT LP1-38) TO BE WIRED THROUGH EMERGENCY POWER SUPPLIES LOCATED IN CUSTODIAL #006 LOCATED IN BASEMENT (SEE DWG. No. E1.01) FOR EMERGENCY OPERATION FOR A MINIMUM OF 1 1/2 HRS. IN THE EVENT OF A POWER FAILURE.
- COORDINATE THE LOCATION OF ALL SWITCHES, RECEPTACLES, EXIT SIGNS, STROBES ETC WITH THE FURNITURE LAYOUTS PROVIDED BY THE ARCHITECT PRIOR TO ROUGH-IN.

ALL WORK IN THIS AREA TO BE INCLUDED IN ALTERNATE #3 ONLY - SEE SITE PLAN DWG. No. SJ1.1 FOR BASE BID REQUIREMENTS

'E' FIXTURES IN THIS AREA TO BE MOUNTED ON VERTICAL FACE OF UPPER WALL - SEE ARCHITECTURAL SECTIONS

LOCATE SWITCH BANK HERE - SEE NOTE #1

SEE NOTE #6 FOR TRACK  
LP1-26 & 28 (a&b)  
LP1-26 & 28 (c&d)

SEE NOTE #5 FOR TRACK

SEE NOTE #7 FOR TRACK

THIS IS FOR ALTERNATE #2 - OTHERWISE, THIS IS A THREE WAY KEY SWITCH

THIS FOR ALTERNATE #2 ONLY

UP TO FIXTURES - SEE DWG. No. E1.03

PROPOSED LIBRARY BUILDING FOR  
**SOUTHURY PUBLIC LIBRARY**  
SOUTHURY, CONNECTICUT

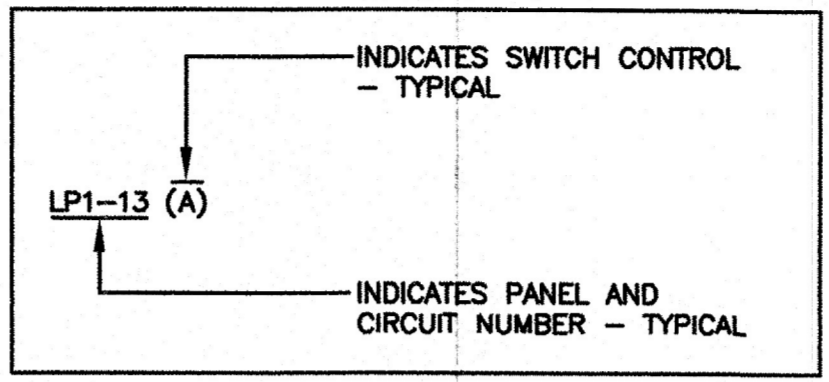
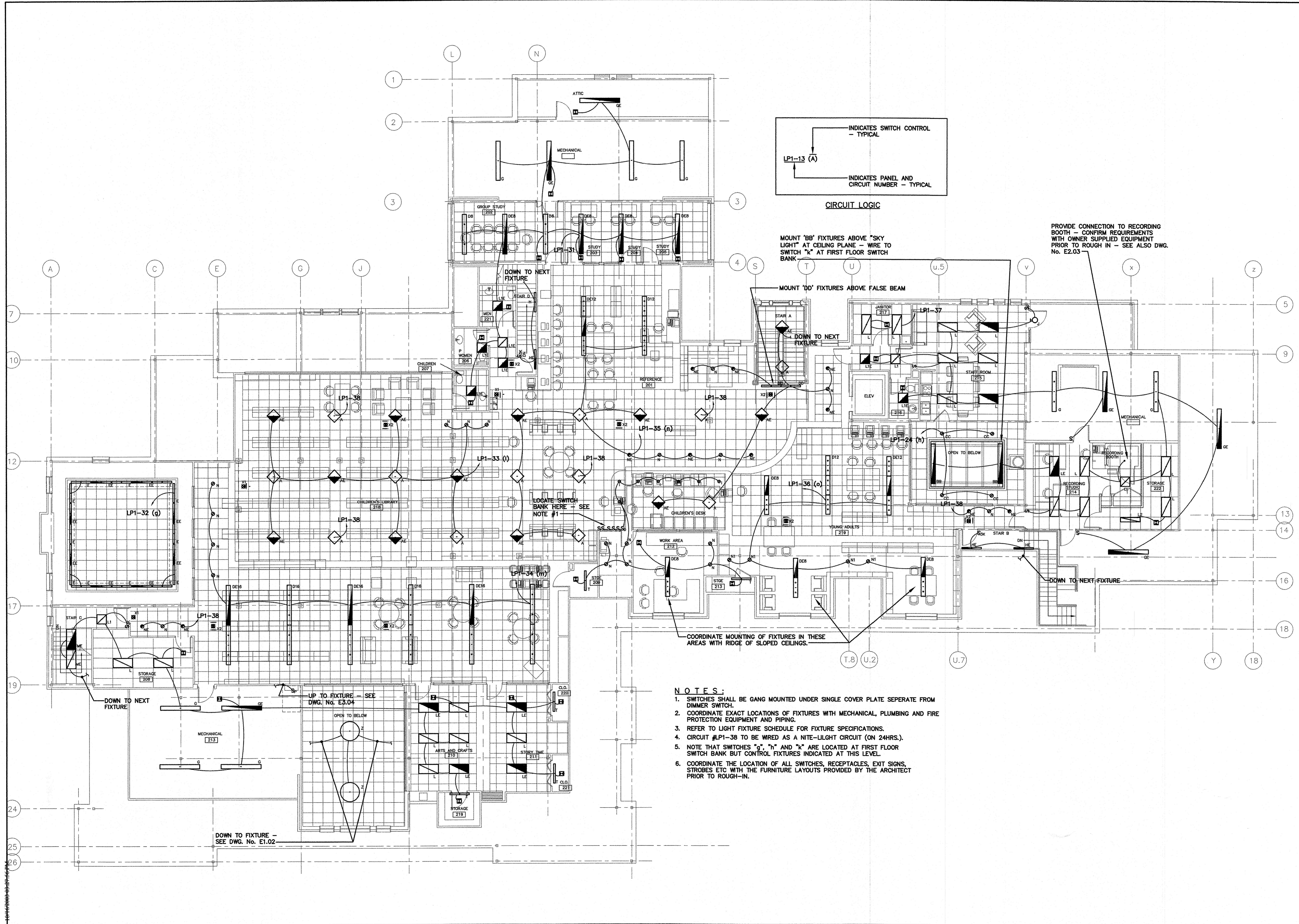

CIRCUIT LOGIC

MOUNT 'BB' FIXTURES ABOVE "SKY LIGHT" AT CEILING PLANE - WIRE TO SWITCH "k" AT FIRST FLOOR SWITCH BANK

PROVIDE CONNECTION TO RECORDING BOOTH - CONFIRM REQUIREMENTS WITH OWNER SUPPLIED EQUIPMENT PRIOR TO ROUGH IN - SEE ALSO DWG. No. E2.03

MOUNT 'DD' FIXTURES ABOVE FALSE BEAM

LOCATE SWITCH BANK HERE - SEE NOTE #1

COORDINATE MOUNTING OF FIXTURES IN THESE AREAS WITH RIDGE OF SLOPED CEILINGS.

NOTES:

- 1. SWITCHES SHALL BE GANG MOUNTED UNDER SINGLE COVER PLATE SEPERATE FROM DIMMER SWITCH.
- 2. COORDINATE EXACT LOCATIONS OF FIXTURES WITH MECHANICAL, PLUMBING AND FIRE PROTECTION EQUIPMENT AND PIPING.
- 3. REFER TO LIGHT FIXTURE SCHEDULE FOR FIXTURE SPECIFICATIONS.
- 4. CIRCUIT #LP1-38 TO BE WIRED AS A NITE-LIGHT CIRCUIT (ON 24HRS.).
- 5. NOTE THAT SWITCHES "g", "h" AND "k" ARE LOCATED AT FIRST FLOOR SWITCH BANK BUT CONTROL FIXTURES INDICATED AT THIS LEVEL.
- 6. COORDINATE THE LOCATION OF ALL SWITCHES, RECEPTACLES, EXIT SIGNS, STROBES ETC WITH THE FURNITURE LAYOUTS PROVIDED BY THE ARCHITECT PRIOR TO ROUGH-IN.



Area Description	Unit Quantity Before		Watts/ Unit Before	Annual Hours Before (Verify if over 6000)	"New Occupancy Sensor (Y or N)	Watts/ Unit After
001 FAR END STAIRS 2ND FL	1	Fluorescent, 2L 4 FT, 32W T8, Instant Start Ballast, NLO (BF: .85-.95)	60	8,760	Y	13
001 FAR END STAIRS 2ND FL	1	Fluorescent, 2L 4 FT, 32W T8, Instant Start Ballast, NLO (BF: .85-.95)	60	8,760	Y	13
003 MENS WALL LANDING	1	Fluorescent, 2L 4 FT, 32W T8, Instant Start Ballast, NLO (BF: .85-.95)	60	8,760	Y	13
003 MENS WALL LANDING	1	Fluorescent, 2L 4 FT, 32W T8, Instant Start Ballast, NLO (BF: .85-.95)	60	8,760	Y	13
005 CENTER STAIRS 2ND FL	2	Fluorescent, 2L 4 FT, 32W T8, Instant Start Ballast, NLO (BF: .85-.95)	60	8,760	Y	13
005 CENTER STAIRS 2ND FL	1	Fluorescent, 2L 4 FT, 32W T8, Instant Start Ballast, NLO (BF: .85-.95)	60	8,760	Y	13
005 CENTER STAIRS 2ND FL	6	LED, 15W lamp	15	8,760	Y	13
005 CENTER STAIRS 2ND FL	2	LED, 15W lamp	15	8,760	Y	13
005 CENTER STAIRS 2ND FL	2	LED, 15W lamp	15	8,760	Y	13
010 RIGHT STAIRS 2ND FL	1	Fluorescent, 2L 4 FT, 32W T8, Instant Start Ballast, NLO (BF: .85-.95)	60	8,760	Y	13
010 RIGHT STAIRS 2ND FL	1	Fluorescent, 2L 4 FT, 32W T8, Instant Start Ballast, NLO (BF: .85-.95)	60	8,760	Y	13
010 RIGHT STAIRS 2ND FL	2	Fluorescent, 2L 4 FT, 32W T8, Instant Start Ballast, NLO (BF: .85-.95)	60	8,760	Y	13
010 RIGHT STAIRS 2ND FL	1	Fluorescent, 2L 4 FT, 32W T8, Instant Start Ballast, NLO (BF: .85-.95)	60	8,760	Y	13
014 RESTROOM #1	1	Fluorescent, 2L 2 FT, 17W T8, Instant Start Ballast, NLO (BF: .85-.95)	32	4,043	Y	10
014 RESTROOM #1	1	Fluorescent, 2L 4 FT, 32W T8, Instant Start Ballast, NLO (BF: .85-.95)	60	4,043	N	23
016 PROGRAM ROOM	27	LED, 15W lamp	15	2,021	N	32
017 PAPER SON	2	Fluorescent, 2L 4 FT, 32W T8, Instant Start Ballast, NLO (BF: .85-.95)	60	2,021	N	13
019 CENTER OFFICE	4	Compact Fluorescent, Quad, 2L 9W	22	2,021	N	13
021 ELECTBOOKS STORAGE	2	Fluorescent, 2L 4 FT, 32W T8, Instant Start Ballast, NLO (BF: .85-.95)	60	505	N	32
022 RESTROOM	1	Fluorescent, 2L 2 FT, 17W T8, Instant Start Ballast, NLO (BF: .85-.95)	32	4,043	N	23
023 LUNCH	6	Fluorescent, 2L 4 FT, 32W T8, Instant Start Ballast, NLO (BF: .85-.95)	60	4,043	Y	32
024 RR & LUNCH HALLWAY	2	Fluorescent, 2L 4 FT, 32W T8, Instant Start Ballast, NLO (BF: .85-.95)	60	2,021	N	23
025 FRONT OF ELEVATORS	2	Compact Fluorescent, Twin, 2L 32W	68	3,032	N	13
025 FRONT OF ELEVATORS	3	Compact Fluorescent, Twin, 2L 32W	68	3,032	N	13
025 FRONT OF ELEVATORS	1	LED, 18W lamp	18	3,032	N	13
025 FRONT OF ELEVATORS	3	LED, 18W lamp	18	3,032	N	13
029 FRONT RIGHT	6	Fluorescent, 3L 4 FT, 32W T8, Instant Start Ballast, NLO (BF: .85-.95)	88	3,032	N	13
031 DESK	8	Compact Fluorescent, Twin, 2L 32W	68	3,032	N	13
031 DESK	1	Compact Fluorescent, Twin, 2L 32W	68	3,032	N	13
031 DESK	8	Compact Fluorescent, Twin, 2L 32W	68	3,032	N	13
034 BY RESTROOM	11	Compact Fluorescent, Twin, 2L 32W	68	3,032	N	13

Area Description	Unit Quantity Before		Watts/ Unit Before	Annual Hours Before (Verify if over 6000)	"New Occupancy Sensor (Y or N)	Watts/ Unit After
034 BY RESTROOM	3	Compact Fluorescent, Twin, 2L 32W	68	3,032	N	13
034 BY RESTROOM	1	Compact Fluorescent, Twin, 2L 32W	68	3,032	N	13
034 BY RESTROOM	2	Fluorescent, 2L 4 FT, 32W T8, Instant Start Ballast, NLO (BF: .85-.95)	60	3,032	N	23
038 2ND FLOOR	8	Fluorescent, 3L 4 FT, 32W T8, Instant Start Ballast, NLO (BF: .85-.95)	88	3,032	N	13
038 2ND FLOOR	21	Fluorescent, 3L 4 FT, 32W T8, Instant Start Ballast, NLO (BF: .85-.95)	88	3,032	N	13
038 2ND FLOOR	12	Fluorescent, 3L 4 FT, 32W T8, Instant Start Ballast, NLO (BF: .85-.95)	88	3,032	N	13
043 MAIN LEVEL A&B COMMUNITY RM	3	Fluorescent, 2L 4 FT, 32W T8, Instant Start Ballast, NLO (BF: .85-.95)	60	1,263	N	23
043 MAIN LEVEL A&B COMMUNITY RM	12	Fluorescent, 2L 4 FT, 32W T8, Instant Start Ballast, NLO (BF: .85-.95)	60	1,263	N	32
043 MAIN LEVEL A&B COMMUNITY RM	6	LED, 18W lamp	18	1,263	N	13
043 MAIN LEVEL A&B COMMUNITY RM	10	LED, 18W lamp	18	1,263	N	13
047 TABLE STORAGE	2	Fluorescent, 2L 4 FT, 32W T8, Instant Start Ballast, NLO (BF: .85-.95)	60	505	N	13
048 SHIRLEY	3	Fluorescent, 3L 4 FT, 32W T8, Instant Start Ballast, NLO (BF: .85-.95)	88	505	N	13
049 HALLWAY	1	Compact Fluorescent, Twin, 2L 32W	68	3,032	N	13
049 HALLWAY	3	LED, 18W lamp	18	3,032	N	13
051 OFFICE	1	Fluorescent, 4L 4 FT, 32W T8, Instant Start Ballast, NLO (BF: .85-.95)	112	3,032	N	13
052 DESK	9	Compact Fluorescent, Twin, 2L 26W	54	3,032	N	13
052 DESK	3	Compact Fluorescent, Twin, 2L 32W	68	3,032	N	13
054 BY 2ND FL STAIRS	4	Compact Fluorescent, Twin, 2L 32W	68	3,032	N	13
054 BY 2ND FL STAIRS	9	LED, 18W lamp	18	3,032	N	13
057 BROWN CONF. ROOM	1	Fluorescent, 2L 4 FT, 32W T8, Instant Start Ballast, NLO (BF: .85-.95)	60	3,032	N	23
057 BROWN CONF. ROOM	6	Fluorescent, 3L 4 FT, 32W T8, Instant Start Ballast, NLO (BF: .85-.95)	88	3,032	N	32
059 ENTRY VESTIBULE	6	Compact Fluorescent, Twin, 2L 32W	68	8,760	N	13
060 VESTIBULE TO A&B	2	Compact Fluorescent, Twin, 2L 32W	68	3,032	Y	13
060 VESTIBULE TO A&B	2	LED, 18W lamp	18	3,032	Y	13
062 MENS RR	4	Fluorescent, 2L 4 FT, 32W T8, Instant Start Ballast, NLO (BF: .85-.95)	60	3,032	Y	32
063 RESTROOM HALLWAY	6	Fluorescent, 2L 4 FT, 32W T8, Instant Start Ballast, NLO (BF: .85-.95)	60	3,032	Y	32
063 RESTROOM HALLWAY	3	LED, 18W lamp	18	3,032	N	13
065 LADIES VESTIBULE	1	Compact Fluorescent, Twin, 2L 32W	68	1,263	N	13
065 LADIES VESTIBULE	5	Fluorescent, 2L 4 FT, 32W T8, Instant Start Ballast, NLO (BF: .85-.95)	60	1,263	N	32
067 REFERENCE OFFICE	6	Fluorescent, 3L 4 FT, 32W T8, Instant Start Ballast, NLO (BF: .85-.95)	88	3,032	N	13
068 CIRCULATION	6	Fluorescent, 3L 4 FT, 32W T8, Instant Start Ballast, NLO (BF: .85-.95)	88	3,032	N	13

Area Description	Unit Quantity Before		Watts/ Unit Before	Annual Hours Before (Verify if over 6000)	"New Occupancy Sensor (Y or N)	Watts/ Unit After
069 FRIENDS & VOLUNTEERS	1	Fluorescent, 3L 4 FT, 32W T8, Instant Start Ballast, NLO (BF: .85-.95)	88	3,032	N	32
069 FRIENDS & VOLUNTEERS	3	Fluorescent, 3L 4 FT, 32W T8, Instant Start Ballast, NLO (BF: .85-.95)	88	3,032	N	13
070 COATS	1	Fluorescent, 2L 4 FT, 32W T8, Instant Start Ballast, NLO (BF: .85-.95)	60	3,032	N	32
071 RESTROOM	1	Fluorescent, 2L 4 FT, 32W T8, Instant Start Ballast, NLO (BF: .85-.95)	60	1,263	N	32
072 TECH SERVICES	6	Fluorescent, 3L 4 FT, 32W T8, Instant Start Ballast, NLO (BF: .85-.95)	88	3,032	Y	13
072 TECH SERVICES	2	Fluorescent, 3L 4 FT, 32W T8, Instant Start Ballast, NLO (BF: .85-.95)	88	3,032	Y	13
075 Supply Closet	1	Fluorescent, 2L 4 FT, 32W T8, Instant Start Ballast, NLO (BF: .85-.95)	60	505	N	32
076 HALLWAY	5	Fluorescent, 2L 4 FT, 32W T8, Instant Start Ballast, NLO (BF: .85-.95)	60	3,032	N	32
079 REDERENCE	6	Compact Fluorescent, spiral, 1L 18W	18	3,032	N	13
080 WALL TRACK LTS	10	Metal Halide, 1L 35W	44	3,032	N	10
080 MAIN LIBRARY	87	Fluorescent, 3L 4 FT, 32W T8, Instant Start Ballast, NLO (BF: .85-.95)	88	3,032	N	13
080 MAIN LIBRARY	2	Fluorescent, 3L 4 FT, 32W T8, Instant Start Ballast, NLO (BF: .85-.95)	88	3,032	Y	13
083 BASEMENT SW#1	15	Fluorescent, 4L 4 FT, 32W T8, Instant Start Ballast, NLO (BF: .85-.95)	112	1,516	N	13
083 BASEMENT SW#1	6	LED, 18W lamp	18	1,516	N	13
081 MAIN LIBRARY						
084 BASEMENT SW#2	36	Fluorescent, 4L 4 FT, 32W T8, Instant Start Ballast, NLO (BF: .85-.95)	112	1,516	Y	13
084 BASEMENT SW#2	12	LED, 18W lamp	18	1,516	Y	13
085 BOOKS TO SHIP	2	Induction, 1L 40W	40	1,516	N	36
085 BOOKS TO SHIP	32	LED, 18W lamp	18	1,516	Y	13
087 BASEMENT	4	Fluorescent, 4L 4 FT, 32W T8, Instant Start Ballast, NLO (BF: .85-.95)	112	1,516	Y	13
087 BASEMENT	8	Induction, 1L 40W	40	1,516	N	36